



**TimeSmart**<sup>®</sup>  
Tips Inside!

# Use & Care

G U I D E

## Self-Cleaning Gas Range

A Note to You .....	2
Range Safety .....	3-5
Parts and Features ....	6
Using Your Range .....	7
Using the Self-Cleaning Cycle.....	27
Caring for Your Range .....	31
Troubleshooting .....	37
Requesting Assistance or Service .....	39
Index .....	43
Warranty .....	44

**1-800-253-1301**

Call our Consumer Assistance Center with questions or comments.

TO THE INSTALLER: PLEASE LEAVE THIS INSTRUCTION BOOK WITH THE UNIT.

TO THE CONSUMER: PLEASE READ AND KEEP THIS BOOK FOR FUTURE REFERENCE.

**Super Capacity 465** with AccuBake System

4.65 Cubic Foot Oven

**MODEL SF395LEE**

**PART NO. 3196293 Rev. B**



Making Your World  
A Little Easier.™

[www.WhirlpoolAppliances.com](http://www.WhirlpoolAppliances.com)

# A NOTE TO YOU

## Thank you for buying a WHIRLPOOL® appliance.

Because your life is getting busier and more complicated, WHIRLPOOL appliances are easy to use, save time, and help you manage your home better. To ensure that you enjoy years of trouble-free operation, we developed this Use and Care Guide. It is full of valuable information about how to operate and maintain your appliance properly and safely. Please read it carefully.

Also, complete and mail the **Product Registration Card** provided with your appliance. The card helps us notify you about any new information on your appliance.

## Please record your model's information.

Whenever you call to request service for your appliance, you need to know your complete model number and serial number. You can find this information on the model and serial number label/plate (see the diagram in the "Parts and Features" section). Also, record the other information shown in the next column.

**TimeSmart® TIPS**

*Look for these tips!*

Look for these Time Smart Tips located throughout your Use and Care Guide. They will help you save time and make the most of your new appliance.

Model Number \_\_\_\_\_

Serial Number \_\_\_\_\_

Purchase Date \_\_\_\_\_

Dealer Name \_\_\_\_\_

Dealer Address \_\_\_\_\_

Dealer Phone \_\_\_\_\_

Keep this book and the sales slip together in a safe place for future reference.

Our Consumer Assistance Center number is toll free. **1-800-253-1301**

**WARNING: If the information in this manual is not followed exactly, a fire or explosion may result causing property damage, personal injury or death.**

- Do not store or use gasoline or other flammable vapors and liquids in the vicinity of this or any other appliance.
- **WHAT TO DO IF YOU SMELL GAS**
  - Do not try to light any appliance.
  - Do not touch any electrical switch; do not use any phone in your building.
  - Immediately call your gas supplier from a neighbor's phone. Follow the gas supplier's instructions.
  - If you cannot reach your gas supplier, call the fire department.
- Installation and service must be performed by a qualified installer, service agency or the gas supplier.

# RANGE SAFETY

## Your safety and the safety of others is very important.

We have provided many important safety messages in this manual and on your appliance. Always read and obey all safety messages.



This is the safety alert symbol.

This symbol alerts you to hazards that can kill or hurt you and others.

All safety messages will be preceded by the safety alert symbol and the word "DANGER" or "WARNING." These words mean:

**⚠ DANGER**

You **will** be killed or seriously injured if you don't follow instructions.

**⚠ WARNING**

You **can** be killed or seriously injured if you don't follow instructions.

All safety messages will identify the hazard, tell you how to reduce the chance of injury, and tell you what can happen if the instructions are not followed.



## ⚠ WARNING

### Tip Over Hazard

A child or adult can tip the range and be killed.

Connect anti-tip bracket to rear range foot.

Reconnect the anti-tip bracket, if the range is moved.

See the installation instructions for details.

Failure to follow these instructions can result in death or serious burns to children and adults.

### Anti-Tip Bracket



Range Foot

Making sure the anti-tip bracket is installed:

- Slide range forward.
- Look for the anti-tip bracket securely attached to floor.
- Slide range back so rear range foot is under anti-tip bracket.

continued on next page

## IMPORTANT SAFETY INSTRUCTIONS

**WARNING:** To reduce the risk of fire, electrical shock, injury to persons, or damage when using the range, follow basic precautions, including the following:

- **WARNING – TO REDUCE THE RISK OF TIPPING OF THE RANGE, THE RANGE MUST BE SECURED BY PROPERLY INSTALLED ANTI-TIP DEVICES. TO CHECK IF THE DEVICES ARE INSTALLED PROPERLY, SLIDE RANGE FORWARD, LOOK FOR ANTI-TIP BRACKET SECURELY ATTACHED TO FLOOR, AND SLIDE RANGE BACK SO REAR RANGE FOOT IS UNDER ANTI-TIP BRACKET.**
- **CAUTION –** Do not store items of interest to children in cabinets above a range or on the backguard of a range – children climbing on the range to reach items could be seriously injured.
- **Proper Installation –** The range, when installed, must be electrically grounded in accordance with local codes or, in the absence of local codes, with the *National Electrical Code, ANSI/NFPA 70*. Be sure the range is properly installed and grounded by a qualified technician.
- This range is equipped with a three-prong grounding plug for your protection against shock hazard and should be plugged directly into a properly grounded receptacle. Do not cut or remove the grounding plug from this plug.
- Disconnect the electrical supply before servicing the appliance.
- Never Use the Range for Warming or Heating the Room.
- Do Not Leave Children Alone – Children should not be left alone or unattended in area where the range is in use. They should never be allowed to sit or stand on any part of the range. Injuries may result from the misuse of appliance doors or drawers such as stepping, leaning, or sitting on the doors or drawers.
- Wear Proper Apparel – Loose-fitting or hanging garments should never be worn while using the range.
- User Servicing – Do not repair or replace any part of the range unless specifically recommended in the manual. All other servicing should be referred to a qualified technician.
- Maintenance – Keep range area clear and free from combustible materials, gasoline, and other flammable vapors and liquids.
- Storage in or on the Range – Flammable materials should not be stored in an oven or near surface units.
- Do Not Use Water on Grease Fires – Smother fire or flame or use dry chemical or foam-type extinguisher.
- Use Only Dry Potholders – Moist or damp potholders on hot surfaces may result in burns from steam. Do not let potholder touch hot heating elements. Do not use a towel or other bulky cloth.
- DO NOT TOUCH SURFACE UNITS OR AREAS NEAR UNITS – Surface units may be hot even though they are dark in color. Areas near surface units may become hot enough to cause burns. During and after use, do not touch, or let clothing or other flammable materials contact surface units or areas near units until they have had sufficient time to cool. Among those areas are the cook-top and surfaces facing the cook-top.
- Use Proper Pan Size – The range is equipped with one or more surface units of different size. Select utensils having flat bottoms large enough to cover the surface unit heating element. The use of undersized utensils will expose a portion of the heating element to direct contact and may result in ignition of clothing. Proper relationship of utensil to burner will also improve efficiency. Top burner flame size should be adjusted so it does not extend beyond the edge of the cooking utensil.
- Never Leave Surface Units Unattended at High Heat Settings – Boilover causes smoking and greasy spillovers that may ignite.
- Make Sure Reflector Pans or Drip Bowls Are in Place – Absence of these pans or bowls during cooking may subject wiring or components underneath to damage.
- Protective Liners – Do not use aluminum foil to line surface unit drip bowls or oven bottoms, except as suggested in the manual. Improper installation of these liners may result in a risk of electric shock, or fire.
- Glazed Cooking Utensils – Only certain types of glass, glass/ceramic, ceramic, earthenware, or other glazed utensils are suitable for range-top service without breaking due to the sudden change in temperature.

– SAVE THESE INSTRUCTIONS –

## IMPORTANT SAFETY INSTRUCTIONS

- Utensil Handles Should Be Turned Inward and Not Extend Over Adjacent Surface Units – To reduce the risk of burns, ignition of flammable materials, and spillage due to unintentional contact with the utensil, the handle of a utensil should be positioned so that it is turned inward, and does not extend over adjacent surface units.
- Use Care When Opening Door – Let hot air or steam escape before removing or replacing food.
- Do Not Heat Unopened Food Containers – Build-up of pressure may cause container to burst and result in injury.
- Keep Oven Vent Ducts Unobstructed.
- Placement of Oven Racks – Always place oven racks in desired location while oven is cool. If rack must be moved while oven is hot, do not let potholder contact hot heating element in oven.
- DO NOT TOUCH HEATING ELEMENTS OR INTERIOR SURFACES OF OVEN – Heating elements may be hot even though they are dark in color. Interior surfaces of an oven become hot enough to cause burns. During and after use, do not touch, or let clothing or other flammable materials contact heating elements or interior surfaces of oven until they have had sufficient time to cool. Other surfaces of the appliance may become hot enough to cause burns – among these surfaces are oven vent openings and surfaces near these openings, oven doors, and windows of oven doors.

### For self-cleaning ranges –

- Do Not Clean Door Gasket – The door gasket is essential for a good seal. Care should be taken not to rub, damage, or move the gasket.
- Do Not Use Oven Cleaners – No commercial oven cleaner or oven liner protective coating of any kind should be used in or around any part of the oven.
- Clean Only Parts Listed in Manual.
- Before Self-Cleaning the Oven – Remove broiler pan and other utensils. Wipe off all excessive spillage before initiating the cleaning cycle.

### For units with ventilating hood –

- Clean Ventilating Hoods Frequently – Grease should not be allowed to accumulate on hood or filter.
- When flaming foods under the hood, turn the fan off. The fan, if operating, may spread the flame.

– SAVE THESE INSTRUCTIONS –

# PARTS AND FEATURES

This section contains captioned pictures of your range. Use them to learn where all parts and features are and what they look like. Use the page references to help you quickly find out more about the part or feature you are interested in.

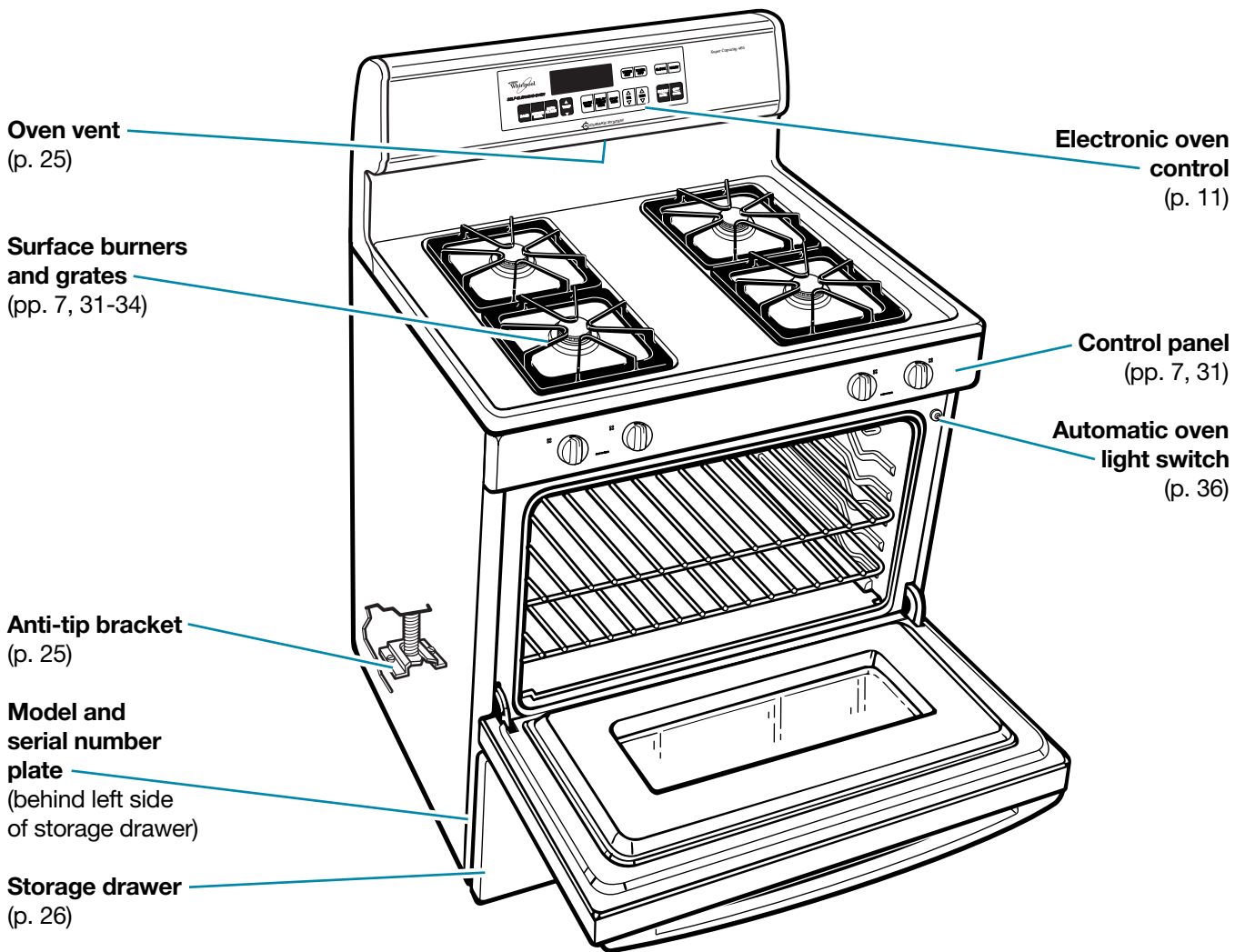

## CONTROL PANEL

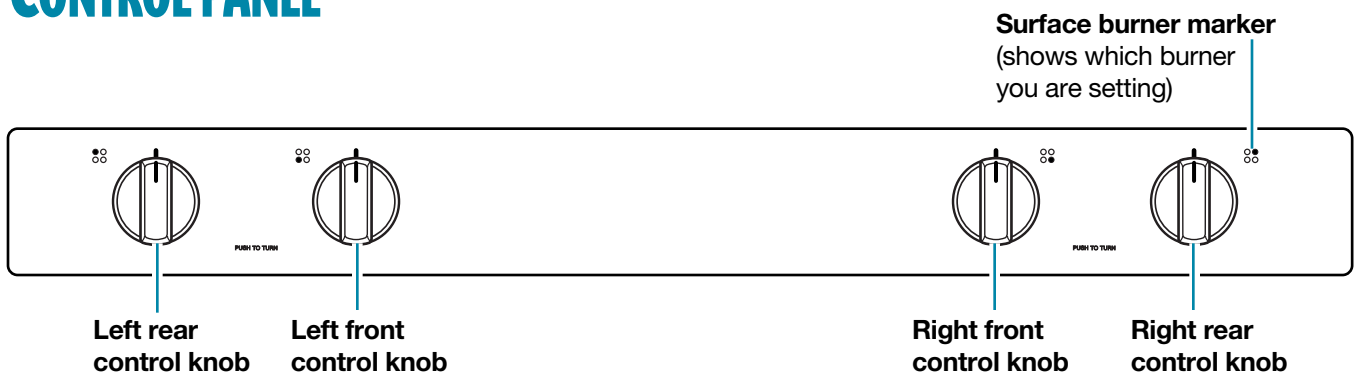

# USING YOUR RANGE

To get the best cooking results, you should use your range the correct way. This section tells you what you need to know to use your range safely and efficiently.

## USING THE SURFACE BURNERS

### ⚠ WARNING

**Carbon Monoxide Poisoning Hazard**  
Do not operate with a yellow flame.  
Doing so can result in death, heart attack, or convulsions.

Your range comes with electric ignitors. Electric ignitors automatically light the burners each time you turn the control knobs to LIGHT.

### Using the control knobs

- Push in the control knob and turn it **counter-clockwise** to the LIGHT position. The clicking sound is the ignitor sparking. Make sure the burner has lit.
- To stop the clicking sound after the burner lights, turn the control knob to the cook setting you want. The control knob has 3 cook settings

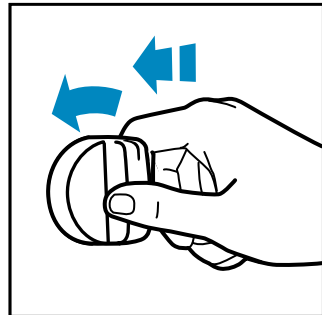

(HIGH, MED, and LOW). However, you can set the control knob anywhere between HIGH and LOW.

**NOTE:** All four electric ignitors will click at the same time. However, the burner with the control knob turned to LIGHT is the one that will ignite.

### Burner heat settings

Use the following chart as a guide.

SETTING	RECOMMENDED USE
LIGHT	<ul style="list-style-type: none"><li>• To light the burner.</li></ul>
HIGH	<ul style="list-style-type: none"><li>• To start foods cooking.</li><li>• To bring liquids to a boil.</li></ul>
MED	<ul style="list-style-type: none"><li>• To hold a rapid boil.</li><li>• To fry chicken or pancakes.</li><li>• For gravy, pudding, and icing.</li><li>• To cook large amounts of vegetables.</li></ul>
LOW*	<ul style="list-style-type: none"><li>• To keep food warm until ready to serve.</li></ul>

### TimeSmart® TIPS

#### Easy ways to save energy

- To help shorten your cooking time, use the least amount of liquid possible.
- Preheat your pots and pans only when recommended and for the shortest time possible.
- Start your food on a higher heat setting, then turn the control to a lower setting to finish cooking.
- Place a filled pan on the burner grate before turning on the surface burner.

### ⚠ WARNING



#### Fire Hazard

**Do not let the burner flame extend beyond the edge of the pan.**  
**Turn off all controls when not cooking.**  
**Failure to follow these instructions can result in death or fire.**

**NOTE:** Do not leave empty cookware, or cookware which has boiled dry, on a hot surface burner. The cookware could overheat, causing damage to the cookware or cooking product.

\* The right rear burner is the AccuSimmer burner and will provide the lowest simmer setting.

## USING THE SURFACE BURNERS (CONT.)

### In case of a prolonged power failure

You can manually light surface burners. Hold a lit match near a burner and turn the control knob to the LIGHT position. After the burner lights, turn the control knob to the setting you want.

### Home canning information

The large diameter of most water-bath or pressure canners combined with high heat settings for long periods of time can cause damage to the cooktop.

#### To protect your range:

- For best results, use a canner which can be centered over the surface burner.
- Do not place your canner on 2 surface burners at the same time. Too much heat will build up and damage the cooktop.
  - Start with hot water. This reduces the time the control is set on high. Reduce the heat setting to the lowest position needed to keep the water boiling.
- Refer to your canner manual for specific instructions.

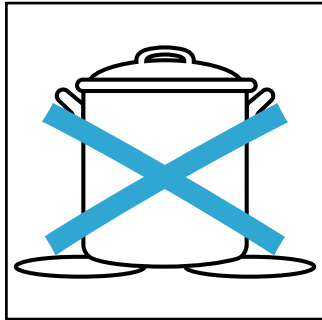

### TimeSmart® TIPS

#### *Using the right cookware makes a big difference*

- The pan should have a flat bottom, straight sides, and a well-fitting lid.
- Choose medium to heavy gauge (thickness) cookware.
- The pan material (metal or glass) affects how quickly and evenly the pan heats.
- When using glass or ceramic cookware, check to make sure it is suitable for use on surface burners.
- To avoid tipping, make sure pots and pans are centered on the grates.

# POSITIONING RACKS AND PANS

## General guidelines

Follow this section carefully to get the best cooking results.

- Before turning on the oven, place oven racks where you need them.
- To move a rack, pull it out to the stop, raise the front edge, and lift it out.
- Be sure the rack(s) is level.
- Use pot holders or oven mitts to protect your hands if rack(s) must be moved while the oven is hot.
- When baking/roasting with 1 rack, place the rack so the top of the food will be centered in the oven.
- When baking/roasting on 2 racks, position racks in oven to allow good circulation of air around all the food.
- Do not place items on the oven door when it is open.

## Extra oven rack position (roasting rack)

Use this rack position when roasting food too large to be placed on the first rack position.

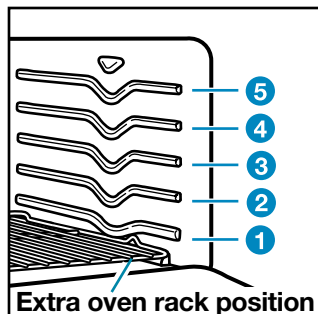

**For proper roasting, follow these guidelines:**

- The rack must be level.
- Use an adequate amount of liquid in the pan (meat juices or water) so your food does not get overdone.
- To pull the rack over the door you must tilt the rack up at the front. If the rack is loaded with food, tilting the rack could cause the food to spill. To avoid spilling, do not try to pull out the rack when removing large amounts of food.

## Rack placement for specific foods:

FOOD	RACK POSITION
Frozen pies, large roasts, turkeys, angel food cakes	1st or 2nd rack guide from bottom
Bundt cakes, most quick breads, yeast breads, casseroles, meats	2nd rack guide from bottom
Cookies, biscuits, muffins, cakes, nonfrozen pies	2nd or 3rd rack guide from bottom

**NOTE:** For information on where to place your rack when broiling, see “Broiling guide” later in this section.

## TimeSmart® TIPS

### Using insulated bakeware, ovenproof glassware, and dark metal pans

- When baking with insulated cookie sheets or baking pans, place them in the bottom third of the oven. You may need to increase the recommended baking times, so test for doneness before removing from the oven.
- When using ovenproof glassware or dark bakeware, reduce the oven temperature by 25°F but use the same baking time. Because these pans absorb heat, producing darker bottom browning and crispier crusts, place the rack in the center of the oven. When baking pies and bread, you can use the temperature suggested in the recipe.

## FOR BEST AIR CIRCULATION

Hot air must circulate around the pans in the oven for even heat to reach all parts of the oven. This results in better baking.

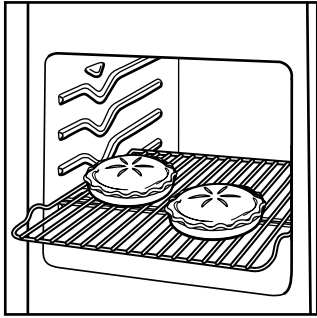

- Place the pans so that one is not directly over the other.
- For best results, allow 1½-2 inches of space around each pan and between pans and oven walls.

For best baking results, bake 1 sheet of cookies at a time using rack 3.

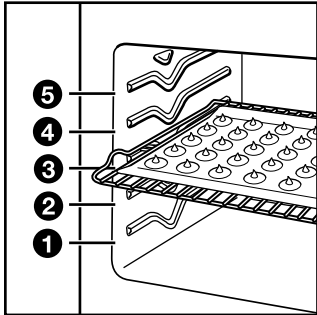

- If baking with 2 cookie sheets, use racks 2 and 4. Increase baking time if necessary.

### Where to place pans:

WHEN YOU HAVE	PLACE
1 pan	In center of the oven rack.
2 pans	Side by side or slightly staggered.
3 or 4 pans	In opposite corners on each oven rack. Stagger pans so no pan is directly over another.

# THE ELECTRONIC OVEN CONTROL

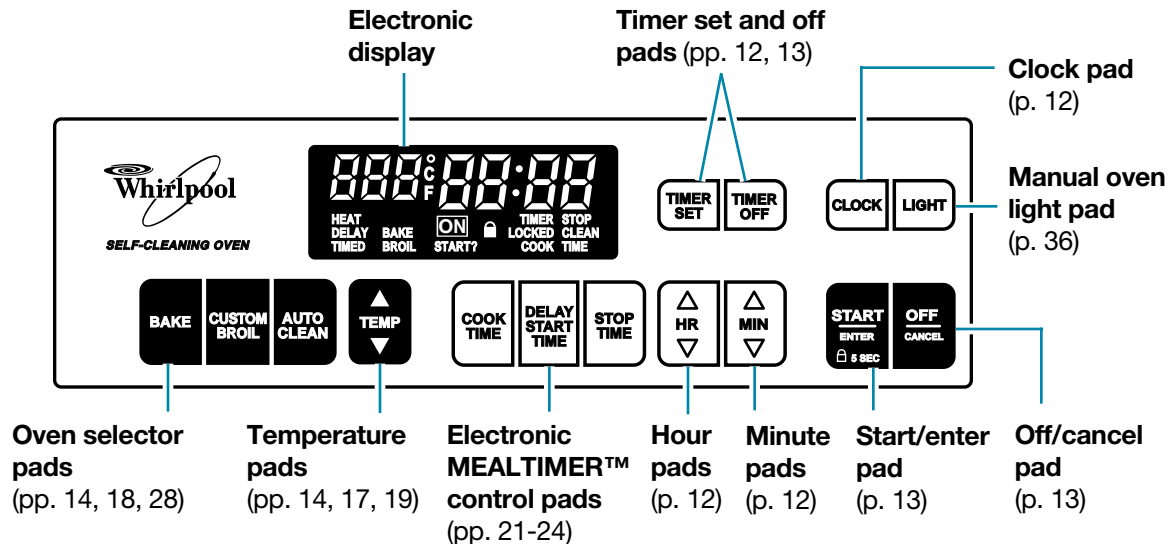

## Display/clock

- When you first plug in the range, everything on the display will light up for 1 to 2 seconds, then a time of day and “PF” will appear on the temperature display. Press the off/cancel pad to clear “PF” from the display. If, after you set the clock (see “Setting the clock” later in this section), “PF” again appears on the display, your electricity was off for a while. Reset the clock, if needed.
- When you are not using the oven, the control is an accurate clock.
- When you are using the oven or minute timer, the display will show times, temperature settings, and what command pads have been pressed.
- When showing the time of day, the display will show the hour and minutes.
- When you are using the minute timer, the display will show minutes and seconds in the following sequence:
  - For settings from 1-59 minutes, the display will count down each second.
  - For settings one hour or over, the display will count down each minute.
- When you are using cook time and/or stop time, the display will show hours and minutes or minutes and seconds.



## Using the control lock

The control lock lets you shut down the control panel command pads. The control lock comes in handy when you want to prevent others from using the oven.

### NOTES:

- You can only use the control lock when the oven is not in use or the control has not been set.
- Set the control lock when cleaning the control panel to prevent yourself from accidentally turning on the oven.
- The control lock will stay on even after a power failure.

### To lock the control panel:

Press and hold the start/enter pad for 5 seconds.



You will hear a single tone and “Loc” and  will appear on the temperature display. When the control is locked, “START?” will appear on the display and 3 tones will sound if you press any command pad other than clock or timer set.

### To unlock the control panel:

Press and hold the start/enter pad for 5 seconds.



You will hear 3 tones followed by a single tone. “Loc” and  will disappear from the temperature display.

## SETTING THE CLOCK

1. Press the clock pad.

PRESS



YOU SEE



2. Set the time.

Press the “up” (▲) or “down” (▼) pad(s) until the correct time shows on the display.

PRESS



YOU SEE



(example for 5:30)

3. Start the clock.

**NOTE:** If you do not want the clock time displayed, press and hold the clock pad for 5 seconds. To display the clock time again, press and hold the clock pad for 5 seconds. You should not have to reset the time. While the clock is not displayed, you can see the clock for 5 minutes by pressing the clock pad.

PRESS



YOU SEE



## USING THE ELECTRONIC MINUTE TIMER

The minute timer does not start or stop the oven. It works like a kitchen timer. It can be set in hours and minutes up to 12 hours, 59 minutes. The minute timer will display minutes and seconds for settings under 1 hour. You will hear four 1-second tones when the set time is up.

1. Press the timer set pad.

PRESS



YOU SEE



2. Set the time.

Press the “up” (▲) or “down” (▼) pad(s) until the correct time shows on the display.

PRESS



YOU SEE



(example for 10 minutes)

## USING THE ELECTRONIC MINUTE TIMER (CONT.)

### 3. Start the minute timer.

The minute timer will begin counting down immediately after the timer is started.

#### PRESS



#### YOU SEE



(display counts down)

When the time is up:

You will hear four 1-second tones, then four 1-second reminder tones every minute until you press the timer off pad.

#### YOU SEE



**NOTE:** To remove the reminder tones, press and hold the timer set pad for 5 seconds. To bring back the tones, follow the same step. You will see “OFF” when the tones are turned off and “on” when they are turned on.

### 4. Turn off the minute timer.

#### PRESS



#### YOU SEE



(time of day)

### To cancel the minute timer:

Press the timer off pad.

#### PRESS



#### YOU SEE



(time of day)

## STARTING/CANCELING A FUNCTION

After setting a function, you must press the start/enter pad to start the function. If you do not press the start/enter pad within 5 seconds of setting, “START?” will show on the display as a reminder.



The off/cancel pad will cancel any function except the clock, timer, or control lock. When you press the off/cancel pad, the display will show the time of day or, if the minute timer is also being used, the time remaining.



# TONES

Tones tell you if a function is entered correctly or not. They also tell you when a cycle is completed.

**To shut off all tones except the end-of-timer and error tones:**

Press and hold the stop time pad for 5 seconds.



A short tone will sound to tell you the tones have been changed. Repeat to turn the tones back on. You will see “oFF” for 3 seconds when the tones are turned off and “on” for 3 seconds when they are turned on.

**To choose between high and low volume tones:**

Press and hold the delay start time pad for 5 seconds.



A short tone will sound to tell you the tones have been changed. Either “HI” or “LO” will appear on the time display for 3 seconds to show the volume you chose.

# BAKING/ROASTING

Your oven is designed with the AccuBake temperature management system to constantly monitor oven temperature. The burner element will cycle, as needed, to maintain the desired temperature. This feature is automatically activated when the oven is in operation.

**IMPORTANT:** Do not try to light the oven burner during a power failure.

1. Place the racks where you need them in the oven.

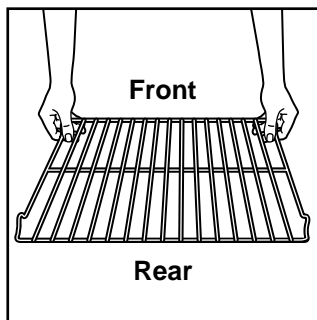

For more information, see “Positioning racks and pans” earlier in this section.

2. Choose the bake setting (optional).

PRESS



YOU SEE



3. Set the temperature (optional).

Do this step if you want to set a temperature other than 350°F. Press the ▲ temp pad to raise the temperature or the ▼ temp pad to lower the temperature in 5°F amounts. Use these pads until the desired temperature shows on the small display.

PRESS



YOU SEE



(example for bake at 375°F)

## BAKING/ROASTING (CONT.)

4. When roasting, put your food in the oven. You do not have to preheat the oven when roasting, unless your recipe recommends it.

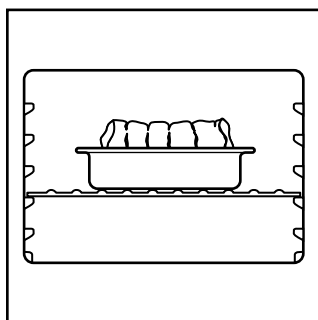

**NOTE:** The oven will cook normally even though the preheat countdown timer is displayed.

### TimeSmart® TIPS

#### Roasting meats and poultry

- For even cooking, place the meat on a rack in a shallow pan. This keeps the meat out of the drippings and allows the heat to circulate better.
- Use a meat thermometer for the most accurate doneness. Insert it so the tip is in the center of the largest muscle or thickest portion of the meat or poultry. Make sure the thermometer is not touching bone, fat, or the bottom of the pan.

5. Press the start/enter pad.

A preheating time will count down on the display. The oven control automatically sets preheating times based on the oven temperature you select:

- For 245°F and less, the preheating time is 4 minutes.
- For 250°F-445°F, the preheating time is 10 minutes.
- For above 450°F, the preheating time is 12 minutes.

As the preheat countdown ends, the selected oven temperature replaces “PrE” on the display and the time of day reappears. You will hear a 1-second tone, indicating the oven is ready to use.

The AccuBake system electronically regulates the preheat time and temperature to maintain a precise temperature range for the best cooking results. The preheat and set temperatures may be different at the end of the countdown. This is normal.

#### NOTES:

- When the oven temperature is greater than 170°F, no preheating time will be shown on the display.
- You can change the temperature setting any time after pressing the start/enter pad. You do not have to press the start/enter pad again.
- The preheating time will not change if you reset the temperature before the countdown time ends.
- If you are baking/roasting while the minute timer is counting down, you can see the set baking/roasting temperature for 5 seconds by pressing the bake pad.

#### PRESS



#### YOU SEE



(example for set temperature of 350°F)

#### YOU SEE



continued on next page

## BAKING/ROASTING (CONT.)

6. When baking, put your food in the oven after the preheat countdown time ends. During baking/roasting, the oven burner will turn on and off to keep the oven temperature at the setting.

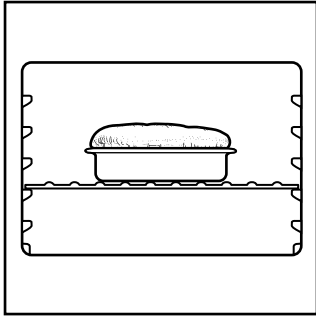

### TimeSmart® TIPS

#### Save energy and save money

- “Oven peeking” can make cooking times longer and affect food quality.
- Rely on a timer to keep track of cooking time.
- Plan your meals for the most efficient use of the oven by cooking more than one food at a time or baking while the oven is still hot after cooking a meal.
- It is not necessary to preheat the oven when broiling or roasting, unless your recipe recommends doing so.

7. After cooking, turn off the oven.

PRESS



YOU SEE



(time of day)

# ADJUSTING THE OVEN TEMPERATURE CONTROL

Although your new oven is properly adjusted to provide accurate temperatures, it may cook faster or slower than your old oven.

If you are not satisfied with the baking/roasting results, you can change the offset temperature by following the steps below.

**NOTE:** DO NOT measure the oven temperature with a thermometer. Opening the oven door will lower the oven temperature and give you an incorrect reading. Also, the thermometer temperature reading will change as your oven cycles.

1. Press and hold the bake pad for 5 seconds.  
The display will show the current offset temperature, for example "0," if you have not already adjusted the temperature.

**PRESS**



**YOU SEE**



(factory setting of "0")

2. Set the new offset temperature.  
Press the ▲ temp pad to raise the temperature or the ▼ temp pad to lower the temperature in 10°F amounts. You can set the temperature change to as low as -30°F or as high as +30°F. A minus (-) sign will appear before the number when decreasing the temperature setting. The minus sign shows the oven will be cooler by the displayed amount. There is no sign in front of the number when increasing the temperature setting.

**PRESS**



**YOU SEE**



(example when making oven 10°F cooler)

3. Enter the adjustment.  
**NOTE:** You must press the start/enter pad or your changes will not be made.

**PRESS**



**YOU SEE**



(time of day)

## To display temperatures in °C instead of °F:

Press and hold the custom broil pad for 5 seconds.

You will hear a short tone and the temperatures displayed will switch to °C. To switch back to °F, repeat the instructions above. Whenever you switch, "°C" or "°F" will be displayed for 5 seconds.



## How to determine the amount of adjustment needed

The chart at the right tells you how much to adjust the offset temperature to get the cooking results you want. You can figure out cooking results by the amount of browning, moistness, and rising times for baked foods.

TO COOK FOOD ...	ADJUST BY THIS NUMBER OF DEGREES (FAHRENHEIT)
A little more	+10
Moderately more	+20
Much more	+30
A little less	-10
Moderately less	-20
Much less	-30

# BROILING

**NOTE:**

- Do not preheat when broiling unless your recipe recommends it.
- See “Broiling tips” later in this section.

1. Place the rack where you need it in the oven.

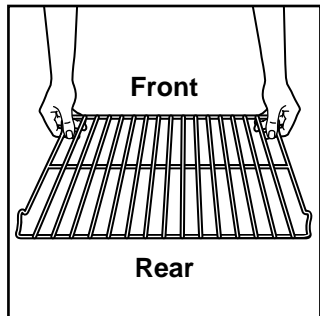

See the “Broiling guide” later in this section.

2. Put your food on the broiler pan and place the

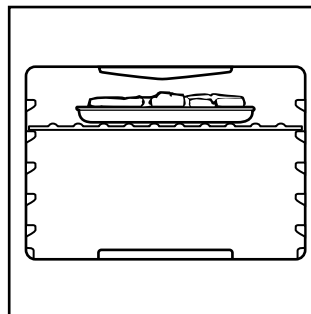

pan in the center of the oven rack.

3. Close the door.

4. Press the custom broil pad.

**PRESS**



**YOU SEE**



5. Start the oven.

You can change the temperature setting any time before or after pressing the start/enter pad. To change the setting, see “To custom broil at a lower temperature” later in this section. After changing the setting, you do not have to press the start/enter pad again.

**PRESS**



**YOU SEE**



6. After broiling, turn off the oven.

**PRESS**



**YOU SEE**



(time of day)

## BROILING (CONT.)

### To custom broil at a lower temperature:

- If your food is cooking too fast, press the ▼ temp pad until “325°F” shows on the small display.

PRESS



YOU SEE



(example shows broil at 325°F)

- If you want your food to broil slower from the start, press the custom broil pad and press the ▼ temp pad so a temperature between 300°F and 525°F shows on the small display. Press the start/enter pad.

Lower temperature settings let the broil heating element cycle and slow cooking. The lower the temperature, the slower the cooking.

**NOTE:** Fish and chicken are some foods that may cook better if you use lower broiling temperatures.

PRESS



YOU SEE



(example shows broil at 400°F)



YOU SEE



## BROILING TIPS

- Use the broiler pan and grid for broiling. They are designed to drain excess liquid and grease away from the cooking surface to help prevent spatter or smoke.
- If you broil small quantities, you may want to use a small broiler pan. You can get them in the housewares section of many department stores.
- Do not cover the broiler grid with foil.
- To make sure the grease drains well, do not use cookie sheets or similar pans for broiling.
- Place food about 3 inches or more from the broil burner.
- The broiling rack position determines how the burner cooks your food. The lower the position, the more broiler grid area covered. See the “Broiling guide” later in this section for more information.
- To sear meat, place the broiler pan at one of the higher rack positions.
- Thin (3/4") steaks may be broiled in the higher rack positions.
- To cook thick (1 1/2") steaks and other thick cuts of meat well done, start cooking on a lower rack position or move them to a lower rack position after searing.
- After broiling, remove the broiler pan from the oven when you remove the food. Drippings will bake on the pan if you leave it in the heated oven.

continued on next page

## BROILING TIPS (CONT.)

### Broiling guide

Recommended rack positions are numbered from the bottom (1) to the top (5). For best results, turn meat after approximately  $\frac{2}{3}$  of the broiling time. Turn chicken pieces after approximately half of the broiling time. Very thin cuts, such as fish fillets, may not need to be turned at all. Lobster tails are not turned.

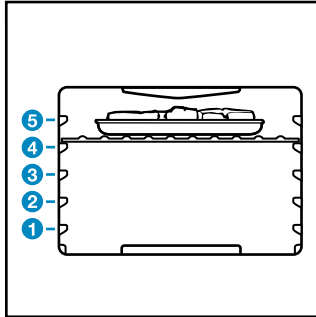

MEAT	RACK POSITION	APPROXIMATE TIME (MINUTES)	
		SIDE 1	SIDE 2
<b>Steak, 1" thick</b>	4		
medium rare		14-15	7-8
medium		15-16	8-9
well done		18-19	9-10
<b>Ground Meat Patties, <math>\frac{3}{4}</math>" thick, well done</b>	4	13-14	6-7
<b>Pork Chops, 1" thick</b>	4	21-22	10-11
<b>Ham Slice, <math>\frac{1}{2}</math>" thick precooked</b>	4	8-10	4-5
<b>Frankfurters</b>	4	6-7	3-4
<b>Lamb Chops, 1" thick</b>	4	15-17	8-9
<b>Chicken</b>			
bone-in pieces	3	18-20	18-20
boneless breasts	4	12-16	11-16
<b>Fish</b>	4		
fillets $\frac{1}{4}$ - $\frac{1}{2}$ " thick		8-10	4-5
steaks $\frac{3}{4}$ -1" thick		15-18	7-9
<b>Lobster Tails, 6-8 oz</b>	3	18-21	N/A

Times are guidelines only and may need to be adjusted for individual tastes.

# USING THE ELECTRONIC MEALTIMER™ CONTROL

The electronic MEALTIMER control will turn the oven on and off at times you set, even when you are not around.

Delayed time baking/roasting is ideal for foods that do not need a preheated oven, like meats and casseroles. **Do not use delayed time cooking for cakes, cookies, etc. – they will not rise properly.**

**Before using the electronic MEALTIMER control, make sure the clock is set to the correct time of day.** (See the “Setting the clock” section.)

## ⚠ WARNING

### Food Poisoning Hazard

**Do not let food sit in oven more than one hour before or after cooking.**

**Doing so can result in death, food poisoning, or sickness.**

## To start baking/roasting now and stop automatically:

1. Place the oven rack(s) where you need them and put your food in the oven. To place your racks correctly, see “Positioning racks and pans” earlier in this section.

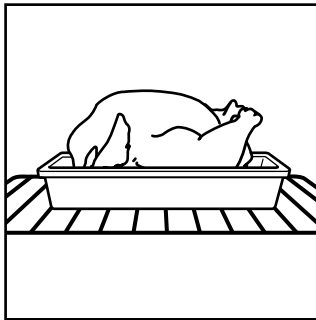

put your food in the oven. To place your racks correctly, see “Positioning racks and pans” earlier in this section.

2. Choose the bake setting.

PRESS



YOU SEE



3. Set the temperature (optional).

Do this step if you want to set a temperature other than 350°F. Press ▲ to raise the temperature or ▼ to lower the temperature in 5°F amounts. Use these pads until the temperature you want shows on the small display.

PRESS



YOU SEE



(example shows bake at 375°F)

4. Press the cook time pad.

PRESS



YOU SEE

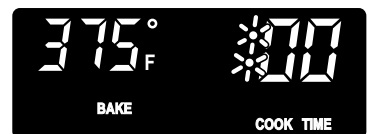

continued on next page

# USING THE ELECTRONIC MEALTIMER™ CONTROL (CONT.)

**5.** Set the cook time.

Press the “up” (▲) or “down” (▼) pad(s) until the correct time shows on the display.

**PRESS**



**YOU SEE**



(example shows 30-minute baking/roasting time)

**6.** Start the oven.

**NOTES:**

- You can change the temperature or time settings any time after pressing the start/enter pad by repeating Steps 3 or 5. You do not have to press the start/enter pad.
- The display will count down the baking/roasting time in hours and minutes (if cook time is more than 1 hour) or in minutes and seconds (if cook time is less than 1 hour).

**PRESS**



**YOU SEE**



(display counts down cook time)

**7.** When baking/roasting is done:

The oven will turn off by itself and beep 4 times. You will also hear four 1-second tones every minute until you press the off/cancel pad.

**NOTE:** To remove the reminder tones, press and hold the cook time pad for 5 seconds. To bring back the tones, repeat this step. You will see “off” when the tones are turned off and “on” when they are turned on.

**YOU SEE**



**8.** Turn off the oven.

**NOTE:** You can do this step any time to cancel the MEALTIMER control setting.

**PRESS**



**YOU SEE**



(time of day)

# USING THE ELECTRONIC MEALTIMER™ CONTROL (CONT.)

## To delay start and stop automatically:

1. Place the oven rack(s) where you need them and put your food in the oven. To place your racks correctly, see “Positioning racks and pans” earlier in this section.

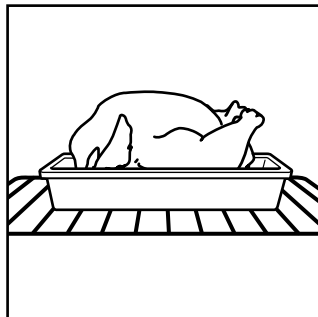

put your food in the oven. To place your racks correctly, see “Positioning racks and pans” earlier in this section.

2. Choose the bake setting.

PRESS



YOU SEE



3. Set the temperature (optional).

Do this step if you want to set a temperature other than 350°F. Press the ▲ temp pad to raise the temperature or the ▼ temp pad to lower the temperature in 5°F amounts. Use these pads until the temperature you want shows on the small display.

PRESS



YOU SEE



(example shows bake at 375°F)

4. Press the cook time pad.

PRESS



YOU SEE



5. Set the cook time.

Press the “up” (▲) or “down” (▼) pad(s) until the correct time shows on the display.

PRESS



YOU SEE

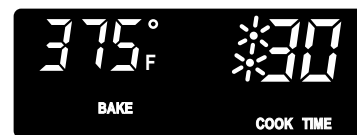

(example shows 30-minute baking/roasting time)

6. Press the delay start time pad.

PRESS



YOU SEE



# USING THE ELECTRONIC MEALTIMER™ CONTROL (CONT.)

**7.** Set the start time.

Press the “up” (▲) or “down” (▼) pad(s) until the correct time shows on the display.

The example at the right shows a chosen start time of 2:00. The oven will shut off by itself at 2:30 (the set start time plus the set cook time).

**PRESS**



**YOU SEE**



(example shows 2:00 start time)

**8.** Press the start/enter pad.

**NOTE:** You can change the temperature or time settings any time after pressing the start/enter pad by repeating Steps 2 through 7.

**PRESS**



**YOU SEE**



**9.** When the start time is reached:

You will hear a 1-second tone. The display will count down the baking/roasting time in hours and minutes (if the cook time is more than 1 hour) or in minutes and seconds (if the cook time is less than 1 hour).

**YOU SEE**



(display counts down cook time)

**10.** When baking/roasting is done:

The oven will turn off by itself and beep 4 times. You will also hear four 1-second tones every minute until you press the off/cancel pad.

**NOTE:** To remove the reminder tones, press and hold the cook time pad for 5 seconds. To bring back the tones, repeat this step. You will see “oFF” when the tones are turned off and “on” when they are turned on.

**YOU SEE**



**11.** Turn off the oven.

**NOTE:** You can do this step any time to cancel the MEALTIMER control setting.

**PRESS**



**YOU SEE**



(time of day)

## THE OVEN VENT

Hot air and moisture escape from the oven through a vent that's near the middle of the backguard. The vent lets air circulate properly. Be careful not to block the vent, or you will get poor baking/roasting results. **NOTE:** Never store plastics, paper, or other items that could melt or burn near the oven vent, or any of the surface burners.

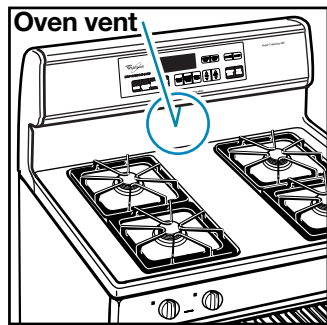

### ! WARNING

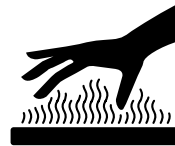

#### Burn Hazard

**Use pot holders when touching items left near oven vent.**  
**Failure to do so can result in burns.**

## THE ANTI-TIP BRACKET

The range will not tip during normal use. However, the range can tip if you apply too much force or weight to the open door without the anti-tip bracket fastened down properly.

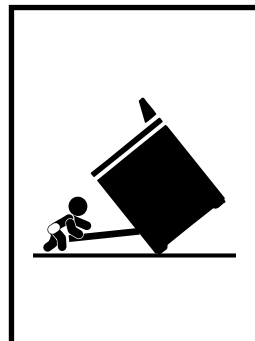

### ! WARNING

#### Tip Over Hazard

**A child or adult can tip the range and be killed.**  
**Connect anti-tip bracket to rear range foot.**  
**Reconnect the anti-tip bracket, if the range is moved.**  
**See the installation instructions for details.**  
**Failure to follow these instructions can result in death or serious burns to children and adults.**

#### Anti-Tip Bracket

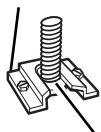

Range Foot

**Making sure the anti-tip bracket is installed:**

- Slide range forward.
- Look for the anti-tip bracket securely attached to floor.
- Slide range back so rear range foot is under anti-tip bracket.

## THE STORAGE DRAWER

You can remove the storage drawer to make it easier to clean under your range. **Be careful when handling the drawer.**

### Removing the storage drawer:

1. Empty the drawer before you remove it. Pull the drawer straight out to the first stop. (The stops are small, round objects formed in the slide rail. They keep the drawer from sliding all the way out.) Then lift the front of the drawer and pull it out to the second stop.
2. Lift the back of the drawer slightly and slide it all the way out.

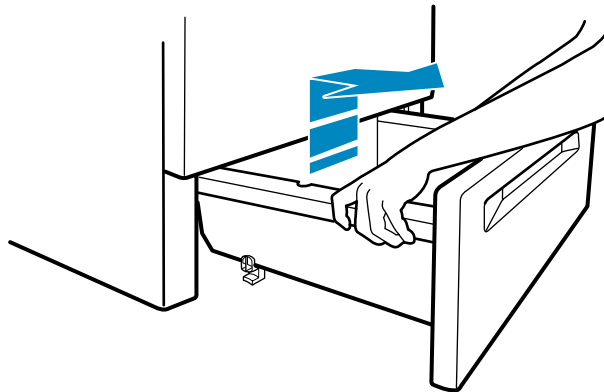

### Replacing the storage drawer:

1. Fit the ends of the drawer slide rails into the drawer guides on both sides of the opening. Also, be sure the lower guide is fitted onto the lower slide rail.
2. Lift the front of the drawer and push it in until the metal stops on the drawer slide rails clear the drawer guides. Then slide the drawer closed.

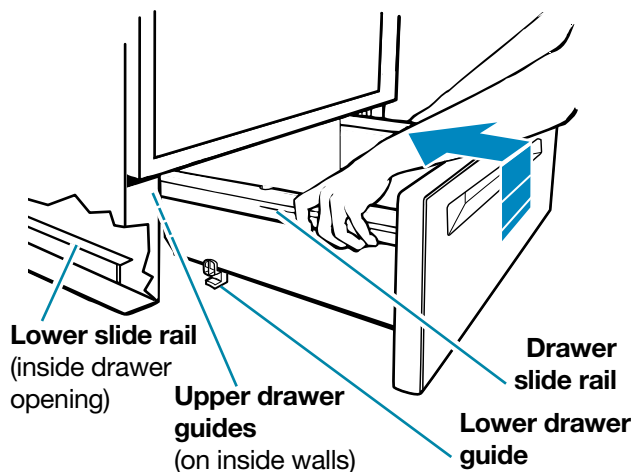

# USING THE SELF-CLEANING CYCLE

The Self-Cleaning cycle saves you from the toil and mess that often come with hand-cleaning the inside of the oven. Like the other functions of your range, you run the Self-Cleaning cycle with the easy-to-use controls. Please review the instructions in this section to keep your oven spotless.

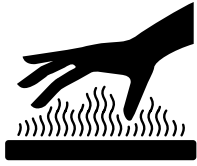

## ⚠ WARNING

### Burn Hazard

- Do not touch the oven during the Self-Cleaning cycle.
- Keep children away from oven during Self-Cleaning cycle.
- Do not use commercial oven cleaners in your oven.
- Failure to follow these instructions can result in burns, or illness from inhaling dangerous fumes.

## BEFORE YOU START

Before you start the Self-Cleaning cycle, make sure you:

- Hand-clean the areas shown. They do not get hot enough during the Self-Cleaning cycle for soil to burn away. Use hot water and detergent or a soapy, steel-wool pad for cleaning.  
**NOTE:** DO NOT clean, move, or bend the gasket. You may get poor cleaning, baking, and roasting.
- Remove the broiler pan and grid and any pots and pans being stored in the oven.
- Wipe out any loose soil or grease. This will help reduce smoke during the Self-Cleaning cycle.
- Wipe up food spills containing sugar as soon as possible after the oven cools down. When sugar is heated to a high temperature in the Self-Cleaning cycle, the high temperature can cause the sugar to burn and react with the porcelain. This can cause staining and etching or pitting.
- Remove the oven racks from the oven if you want them to remain shiny. You can clean the oven racks in the Self-Cleaning cycle, but they will become harder to slide. (See the “Cleaning chart” in the “Caring for Your Range” section.) If you clean the racks in the Self-Cleaning cycle, place them on the 2nd and 4th rack guides. (The guides are counted from bottom to top.)
- Heat and odors are normal during the Self-Cleaning cycle. Keep the kitchen well ventilated by opening a window or by turning on a vent hood or other kitchen vent during the cycle.

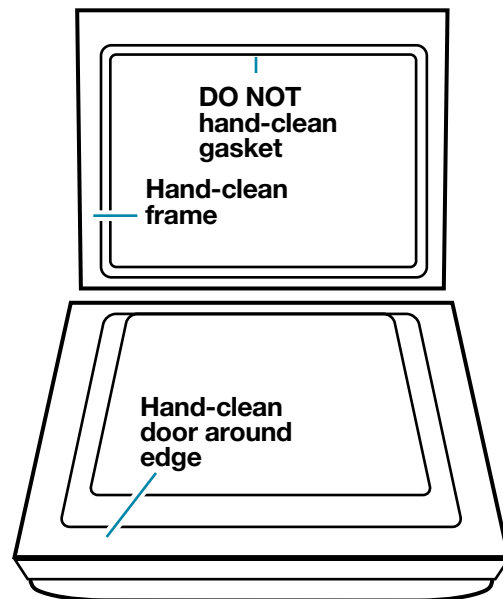

### TIPS:

- Do not block the vent during the Self-Cleaning cycle. Air must move freely for best cleaning results.
- Do not leave plastic utensils on the cooktop. They may melt.
- Do not leave any foil in the oven during the Self-Cleaning cycle. Foil could burn or melt and damage the oven surface.
- The oven light will not work during the Self-Cleaning cycle.

# SETTING THE CONTROLS

**NOTE:** Make sure the clock is set to the correct time of day. (See “Setting the clock” in the “Using Your Range” section.)

## To start cleaning immediately:

1. Press the auto clean pad.

This will automatically set a 3½-hour Self-Cleaning cycle.

**NOTE:** There will be a 30-minute cool-down ½ hour before the cycle is over.

PRESS



YOU SEE



2. Set the cleaning time (optional).

If you want a Self-Cleaning cycle longer or shorter than 3½ hours, use the hour and minute pads to set the cleaning time you want. Press the “up” (▲) or “down” (▼) pad(s) until a time between 2½-4½ hours shows on the display.

- Use 2½ hours for light soil.
- Use 3½-4½ hours for average to heavy soil.

PRESS



YOU SEE



(example shows 4½-hour cleaning time)

3. Start the oven.

Make sure the door is closed all the way. If the door is open even a little, it will not lock. Press the door closed if needed. If the door is closed, it will lock as soon as you press the start/enter pad.

PRESS



YOU SEE

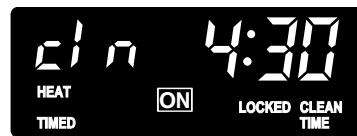

4. After the Self-Cleaning cycle ends:

LOCKED goes off and the door unlocks.

YOU SEE



5. After the oven is cool, wipe off any residue or ash

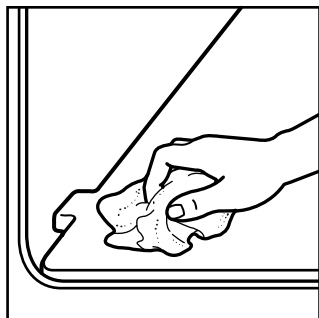

with a damp cloth or sponge. If needed, touch up spots with a mild abrasive cleanser or cleaning sponge.

# SETTING THE CONTROLS (CONT.)

## To delay the start using delay start time:

**1.** Press the auto clean pad.  
This will automatically set a 3½-hour Self-Cleaning cycle.

**NOTE:** There will be a 30-minute cool-down ½ hour before the cycle is over.

**PRESS**



**YOU SEE**



**2.** Set the cleaning time (optional).  
If you want a Self-Cleaning cycle longer or shorter than 3½ hours, use the Hour and Minute pads to set the cleaning time you want. Press the “up” (▲) or “down” (▼) pad(s) until a time between 2½-4½ hours shows on the display.

- Use 2½ hours for light soil.
- Use 3½-4½ hours for average to heavy soil.

**PRESS**



**YOU SEE**



(example for 4½-hour cycle)

**3.** Press the delay start time pad.

**PRESS**



**YOU SEE**



**4.** Set the start time.  
Press the “up” (▲) or “down” (▼) pad(s) until the correct time shows on the display. The oven will automatically come up with the stop time by adding the set cleaning time to the set start time.

**PRESS**



**YOU SEE**



(example for 2:30 start time)

**5.** Press the start/enter pad.

**PRESS**



**YOU SEE**

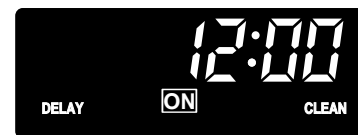

**6.** After the Self-Cleaning cycle starts:  
The door will lock as soon as you press the start/enter pad.

**YOU SEE**



**7.** After the Self-Cleaning cycle ends:  
LOCKED goes off and the door unlocks.

**NOTE:** The stop time will be the start time plus the cleaning time.

**YOU SEE**



## SETTING THE CONTROLS (CONT.)

8. After the oven cools to room temperature, wipe off any residue or ash with a damp cloth or sponge. If needed, touch up spots with a mild abrasive cleanser or cleaning sponge.

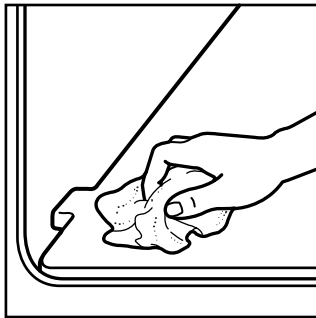

### To stop the self-cleaning cycle at any time:

If the oven temperature is too high for baking/roasting when you press the off/cancel pad, “cln,” TIMED, ON, “cool,” and LOCKED will appear on the display until the oven cools.

#### PRESS



#### YOU SEE



### TimeSmart® TIPS

#### Self-cleaning tips

- Keep the kitchen well ventilated during the Self-Cleaning cycle to help get rid of heat, odors, and smoke.
- Clean the oven before it gets heavily soiled. Cleaning a very soiled oven takes longer and results in more smoke than usual.

## HOW THE CYCLE WORKS

The Self-Cleaning cycle uses very high heat to burn away soil and grease. During the cycle, the oven gets much hotter than it does for normal baking or broiling. This high heat breaks up the soil or grease and burns it away.

Your oven is automatically preset for a 3½-hour Self-Cleaning cycle.

The graph at the right shows you what happens in a 3½-hour Self-Cleaning cycle. Notice that the heating stops ½ hour before the 3½-hour setting is up.

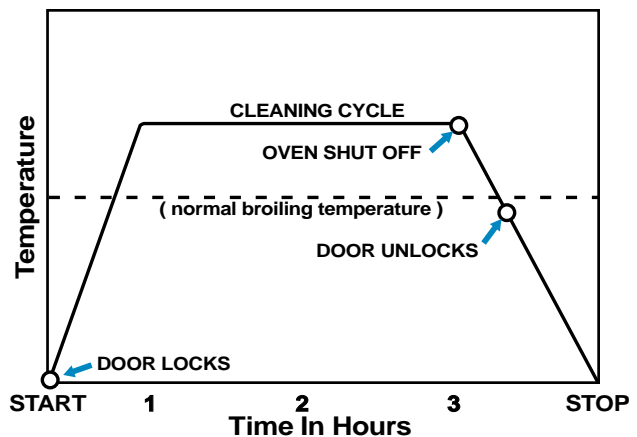

# CARING FOR YOUR RANGE

Your range is designed so you can care for it easily. You can do most cleaning with items found around your home. Cleaning your range whenever spills or soiling occurs will help to keep it looking and working like new.



## ⚠️ WARNING

### Explosion Hazard

Do not store flammable materials such as gasoline near this appliance. Doing so can result in death, explosion, or fire.

## CLEANING CHART

Use this chart to get specific information on cleaning your range. **Before cleaning, always make sure all controls are off and the range is cool.**

PART	HOW TO CLEAN
<b>Control knobs</b>	<ol style="list-style-type: none"> <li>1. Turn the knobs off and pull them straight away from the control panel.</li> <li>2. Wash the knobs with a sponge and warm, soapy water. Rinse and dry them well. Do not soak them. <b>Do not use steel wool or gritty cleansers</b>, which can damage the finish of the knobs.</li> <li>3. Replace the knobs. Make sure all knobs are turned off.</li> </ol>
<b>Control panel</b>	<ul style="list-style-type: none"> <li>● Wash the panel with a sponge and warm, soapy water. Wipe the panel with clean water and dry it well. <b>Do not use steel wool or gritty cleansers</b>, which can damage the finish.</li> </ul> <p><b>OR</b></p> <ul style="list-style-type: none"> <li>● Wash the panel with a paper towel and spray glass cleaner. Do not spray the cleaner directly on the panel. Apply the cleaner to the paper towel.</li> </ul>
<b>Exterior surfaces</b> (other than control panel)	<ul style="list-style-type: none"> <li>● Remove the grates.</li> <li>● Wash the surface with a sponge and warm, soapy water or paper towel and spray glass cleaner. Wipe with clean water and dry thoroughly. Use a nonabrasive, plastic scrubbing pad on heavily soiled areas.</li> <li>● <b>Do not use steel wool, abrasives, or harsh cleansers.</b> They may damage the finish.</li> <li>● If you use soap or detergent solutions, wipe thoroughly to prevent filmy residue.</li> </ul> <p><b>NOTE:</b> Do not let foods containing acids (such as vinegar, tomato, or lemon juice) remain on the surface. Acids may remove the glossy finish. Also, wipe up milk or egg spills when the cooktop is cool. <b>Be careful when cleaning around the model and serial number plate; too much scrubbing could remove the numbers.</b></p> <ul style="list-style-type: none"> <li>● Replace the grates.</li> </ul>
<b>Surface burner grates and caps</b>	<ul style="list-style-type: none"> <li>● Clean as soon as they become dirty and when they are cool enough to handle.</li> <li>● Wash with a mildly abrasive plastic scrubbing pad and warm, soapy water. Rinse and dry well.</li> <li>● For stubborn stains, clean with a scrubbing pad and/or powdered cleanser and water. Repeat these cleaning steps as needed.</li> </ul>
<b>Surface burners</b>	<ul style="list-style-type: none"> <li>● See the “Sealed surface burners and cooktops” section for cleaning instructions.</li> </ul>
<b>Broiler pan and grid</b>	<ul style="list-style-type: none"> <li>● Wash the pan and grid with a steel-wool pad and warm, soapy water. Rinse and dry well.</li> <li>● <b>Do not clean in Self-Cleaning cycle.</b> See “Before you start” in the “Using the Self-Cleaning Cycle” section.</li> </ul> <p><b>OR</b></p> <ul style="list-style-type: none"> <li>● Wash the pan and grid in a dishwasher.</li> </ul>

## CLEANING CHART (CONT.)

PART	HOW TO CLEAN
<b>Oven racks</b>	<ul style="list-style-type: none"> <li>Wash with a steel-wool pad and warm, soapy water. Rinse and dry well.</li> </ul> <p><b>OR</b></p> <ul style="list-style-type: none"> <li>Leave the racks in the oven during the Self-Cleaning cycle.</li> </ul> <p><b>NOTE:</b> If you leave your racks in the oven during the Self-Cleaning cycle, they will lose their original color and become harder to slide. If you need to, apply a small amount of vegetable oil to the side rungs to make the racks easier to slide.</p>
<b>Oven door glass</b>	<ul style="list-style-type: none"> <li>Wash with a paper towel and spray glass cleaner or a nonabrasive plastic scrubbing pad and warm, soapy water. Wipe with clean water and dry well.</li> <li>Follow the directions that come with the cleaner.</li> </ul>
<b>Oven cavity</b>	<ul style="list-style-type: none"> <li>Wipe up food spills containing sugar as soon as possible after the oven cools down. (See the “Using the Self-Cleaning Cycle” section.)</li> <li>See the “Using the Self-Cleaning Cycle” section.</li> </ul>

## SEALED SURFACE BURNERS AND COOKTOP

The sealed burner cooktop is specially designed to make cleaning easier.

### Cleaning the cooktop

- Wipe the cooktop with a damp sponge and dry.

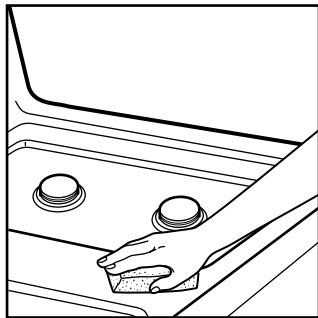

**NOTE:** Do not remove the cooktop. Doing so could result in product damage.

### Cleaning the contoured well areas

The contoured well is an area around each burner that is lower than the rest of the cooktop.

**If spills occur in the contoured well section:**

- Blot up the spill with a paper towel.

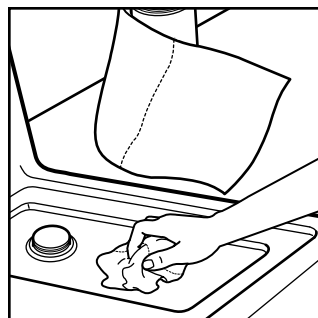

- Wipe up what's left with a clean, damp sponge. Dry.

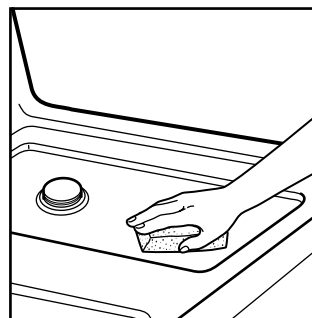

## SEALED SURFACE BURNERS AND COOKTOP (CONT.)

### Cleaning the surface burners

- You should routinely remove and clean the burner cap. Always clean the burner cap after a spill-over. Keeping the burner cap clean prevents improper ignition and an uneven flame.
- For the proper flow of gas and ignition of the burner, **do not allow spills, food, cleaning agents, or any other material to enter the gas tube opening or burner ports.**
- Gas must flow freely through the gas tube opening for the burner to light properly. You must keep this area free of any soil and protect it from boilovers or spillovers. **Always** keep the burner cap in place whenever a surface burner is in use.
- Let the cooktop cool before cleaning.
- Do not use oven cleaners, bleach, or rust removers.
- Do not obstruct the flow of combustion and ventilation air.
- Be careful not to allow moisture to collect in the burner control knob areas. Moisture can cause the ignitor switches to fail.

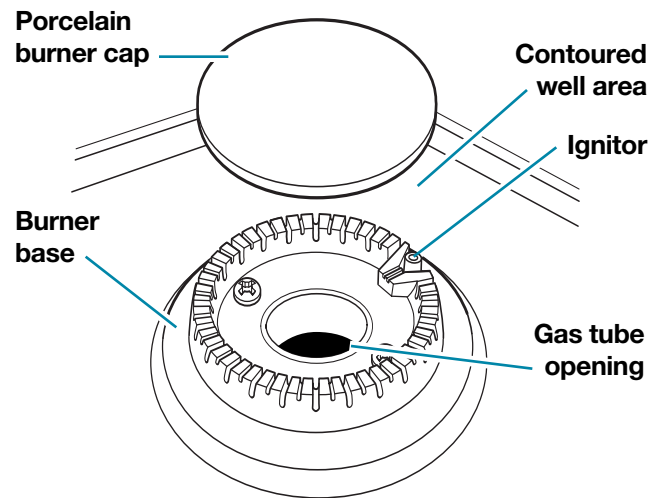

### ⚠ WARNING

**Carbon Monoxide Poisoning Hazard**  
**Do not operate with a yellow flame.**  
**Doing so can result in death, heart attack, or convulsions.**

- Occasionally check the burner flames for proper size and shape as shown.

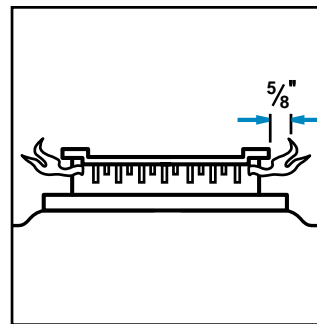

A good flame is blue in color. If the flames are uneven, you may need to clean the burner ports.

## SEALED SURFACE BURNERS AND COOKTOP (CONT.)

### To clean the burners:

1. Pull the burner cap straight up from the burner base.
2. Clean the burner cap with warm, soapy water and a sponge. You can also clean it with a mildly abrasive scrubbing pad or cleanser. Do not clean the burner cap in a dishwasher or self-cleaning oven.
3. If the gas tube opening has become soiled or clogged, use a cotton swab or a soft cloth to clean the area.

4. If the ports are clogged, clean them with a straight pin. Do not enlarge or distort the port. Do not use a wooden toothpick. If the burner needs to be adjusted, call a qualified technician for service.

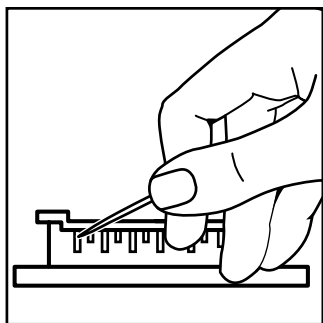

5. After cleaning the gas tube opening and ports, replace the burner cap. To replace the burner cap, make sure the alignment pins on the cap are properly aligned with the burner base.

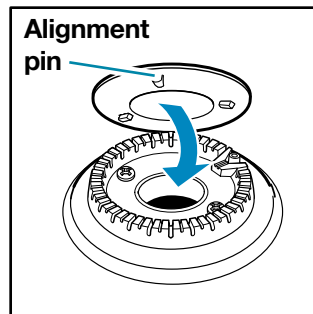

6. Turn on the burner to see if it will light. If the burner does not light after you have cleaned it, recheck cap alignment or contact an authorized service technician. Do not service the sealed burner yourself.

## REMOVING THE OVEN DOOR

For normal use of your range, you do not need to remove the door. However, if you have to remove the door follow the instructions in this section.

**NOTE:** If the door removal pins included in the Anti-Tip Bracket Package are not available, nails or screws may be used. Be careful that the length of the nail or screw does not damage the oven by chipping or scratching the porcelain surface.

Insert door removal pin here

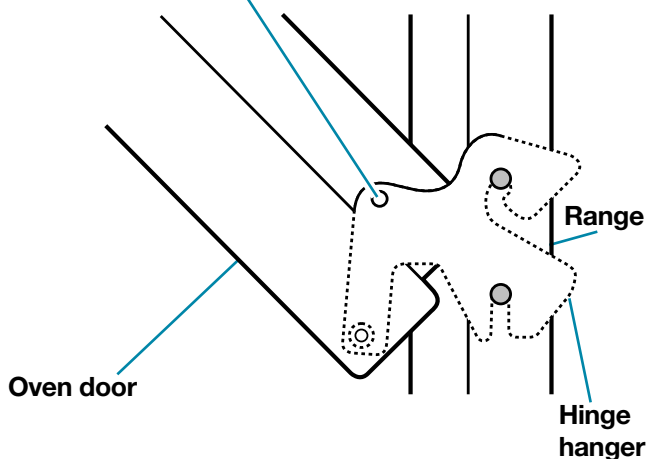

## REMOVING THE OVEN DOOR (CONT.)

### To remove:

1. Open the door about halfway. Insert door removal pins into both hinge hangers. **Do not remove them while the door is removed from the range.**

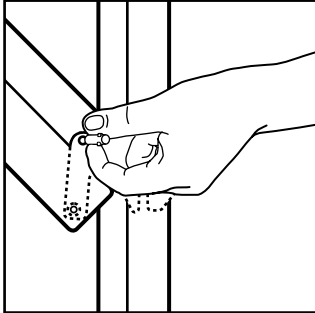

3. Rotate the door toward the range. Lift up the door until it stops. Do not use the door handle to lift the door. Rotate the door toward the floor and pull it toward you.

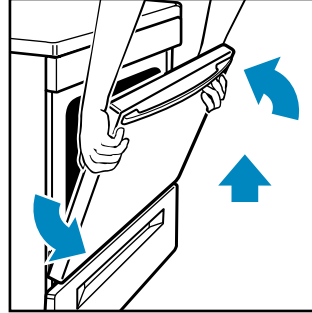

2. Close the door as far as the door removal pins will let you.

### To replace:

**NOTE:** The door removal pins you inserted must still be in both sides of the door.

1. Grasp the door on the sides with your fingers on the front of the door and your thumbs on the inside surface.

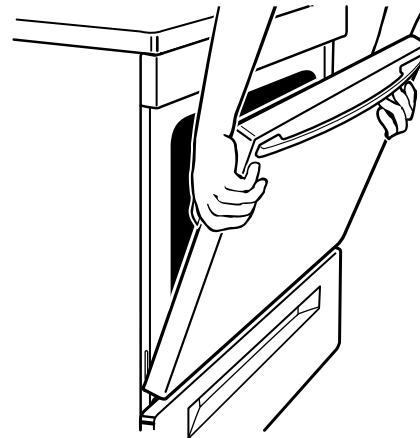

2. Rest the hinge hanger so that it is flat (at the bottom of the hinge hanger on the bottom of the front frame slot).
3. Position the door with the hinge hanger slots almost parallel to the front frame.
4. Push up and in until the hinge hanger slots become fastened to the range. Lower the door and rotate it slightly from the front to the back until the slots are fully fastened. The hinge hanger will be close to the bottom of the front frame slot.
5. Pull door open about halfway and remove the door removal pins. Save door removal pins for future use.
6. Close the door.

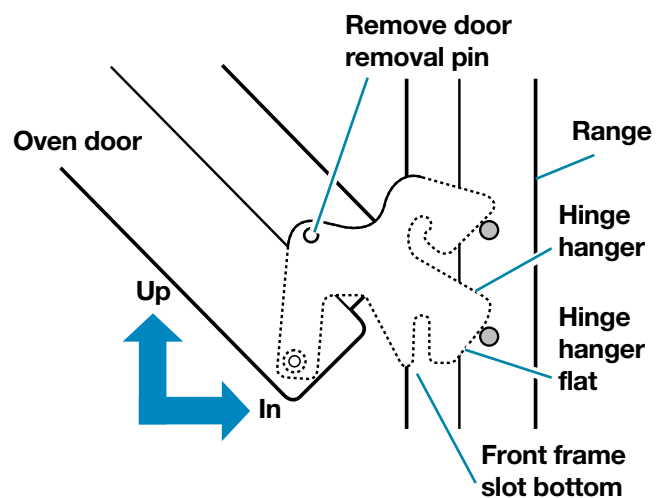

## THE OVEN LIGHT

The oven light will come on when you open the oven door.

### To turn the light on or off when the oven door is closed:

- Press the oven light pad.



### To replace the oven light:

1. Unplug range or disconnect power.
2. Remove the glass bulb cover in the back of the oven by turning it counterclockwise.

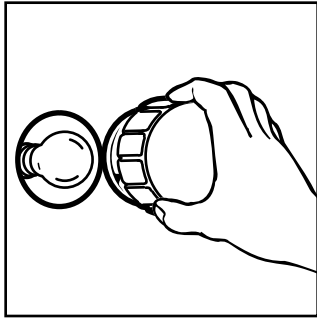

3. Remove the light bulb from its socket. Replace the bulb with a 40-watt appliance bulb.

4. Replace the light bulb cover by turning it clockwise.

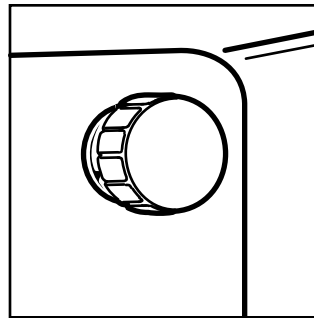

5. Plug in range or reconnect power.

**NOTE:** The oven light will not work during the Self-Cleaning cycle.

# TROUBLESHOOTING

Most cooking problems often are caused by little things you can find and fix without tools of any kind. Check the lists below and on the next page before calling for assistance or service. If you still need help, see “Requesting Assistance or Service” on page 39.

## RANGE DOES NOT WORK

PROBLEM	CAUSE
Nothing works	<ul style="list-style-type: none"><li>• The range is not properly connected to the gas supply. Contact an authorized service technician to reconnect the range to the gas supply. (See the Installation Instructions.)</li><li>• You have blown a household fuse or tripped a circuit breaker.</li><li>• The control knob is not set correctly. Push in the control knobs before turning them.</li></ul>

## OVEN/BROILER BURNER

PROBLEM	CAUSE
The oven does not work	<ul style="list-style-type: none"><li>• You have not set the electronic control correctly. Refer to the proper instructions.</li><li>• You have set a delayed start time. Wait for the start time to be reached or cancel and reset the control.</li><li>• The main or regulator gas shutoff valve is in the off position. (See the Installation Instructions.)</li></ul>
The burner fails to light	<ul style="list-style-type: none"><li>• The ignitor is broken. Contact an authorized service technician to replace it.</li><li>• You have blown a household fuse or tripped a circuit breaker.</li></ul>
The burner flames lift away from the ports, are yellow, or are noisy	<ul style="list-style-type: none"><li>• The air/gas mixture is incorrect. Contact an authorized service technician to check the air/gas mixture or see the Installation Instructions.</li></ul>

## SURFACE BURNERS

PROBLEM	CAUSE
The burner fails to light	<ul style="list-style-type: none"><li>• You have blown a household fuse or tripped a circuit breaker.</li><li>• The burner ports may be clogged. Clean them with a straight pin. (See page 34.)</li></ul>
The burner flames are uneven	<ul style="list-style-type: none"><li>• The burner ports may be clogged. Clean them with a straight pin. (See page 34.)</li></ul>
The burner flames lift off the ports, are yellow, or are noisy when turned off	<ul style="list-style-type: none"><li>• The burner needs cleaning. (See pages 33 and 34.)</li><li>• The air/gas mixture is incorrect. Contact an authorized service technician to check the air/gas mixture or see the Installation Instructions.</li></ul>
The burner makes a popping noise when on	<ul style="list-style-type: none"><li>• The burner is wet from washing. Let it dry.</li></ul>

continued on next page

## WHEN SELF-CLEANING YOUR OVEN

PROBLEM	CAUSE
The Self-Cleaning cycle will not work	<ul style="list-style-type: none"> <li>• You did not press the start/enter pad.</li> <li>• You have set a delayed start time. Wait for the start time to be reached or cancel and reset the control.</li> </ul>

## COOKING RESULTS

PROBLEM	CAUSE
Cooking results are not what you expected	<ul style="list-style-type: none"> <li>• The oven temperature seems too low or too high. See “Adjusting the oven temperature control” on page 17 to adjust the oven temperature.</li> <li>• You did not preheat the oven before baking (if called for in the recipe).</li> <li>• You are using a pan that is not the correct type or size. Refer to a reliable cookbook or recipe for the recommended pan type and size.</li> <li>• There is not enough air space around the pan when baking. Allow 1½ to 2 inches of air space on all sides of the pan.</li> <li>• The flame size does not fit the cookware being used.</li> <li>• When broiling, you have not completely closed the oven door.</li> <li>• The flow of combustion and/or ventilation air to the range is blocked. Make sure nothing is blocking the middle front of the backguard.</li> <li>• The range is not level. (See the Installation Instructions.)</li> </ul>

## DISPLAY MESSAGES

PROBLEM	CAUSE
The display is showing “PF”	<ul style="list-style-type: none"> <li>• There has been a power failure. Press the off/cancel pad to clear the display, then reset the clock. (See page 12.)</li> </ul>
“F” followed by a number shows on the display	<ul style="list-style-type: none"> <li>• Press the off/cancel pad to clear the display. If an “F” code appears again, call for service. (See “If You Need Assistance or Service” on page 39.)</li> </ul>

If none of these items are causing your problem, see “Requesting Assistance or Service” on page 39.

# REQUESTING ASSISTANCE OR SERVICE

To avoid unnecessary service calls, please check the “Troubleshooting” section. It may save you the cost of a service call. If you still need help, follow the instructions below.

## IF YOU NEED ASSISTANCE OR SERVICE

### Call the Whirlpool Consumer Assistance



Center toll free at 1-800-253-1301. Our consultants are available to assist you.

When calling:

Please know the purchase date, and the complete model and serial number of your appliance (see the “A Note to You” section). This information will help us better respond to your request.

### Our consultants provide assistance with:

- Features and specifications on our full line of appliances
- Installation information
- Use and maintenance procedures

- Accessory and repair parts sales
- Do-it-yourself repair help
- Specialized customer assistance (Spanish speaking, hearing impaired, limited vision, etc.)
- Referrals to local dealers, service companies, and repair parts distributors

**Whirlpool service technicians** are trained to fulfill the product warranty and provide after-warranty service, anywhere in the United States.

To locate the authorized Whirlpool service company in your area, you can also look in your telephone directory Yellow Pages.

## IF YOU NEED REPLACEMENT PARTS

If you need to order replacement parts, we recommend that you only use FSP® factory authorized parts. FSP replacement parts will fit right and work right, because they are made to the same exacting specifications used to build every new WHIRLPOOL® appliance.

To locate FSP replacement parts in your area, call our Consumer Assistance Center telephone number or your nearest authorized service center.

## FOR FURTHER ASSISTANCE

If you need further assistance, you can write to Whirlpool with any questions or concerns at:

Whirlpool Brand Home Appliances  
Consumer Assistance Center  
c/o Correspondence Dept.  
2000 North M-63  
Benton Harbor, MI 49022-2692

Please include a daytime phone number in your correspondence.







# INDEX

This index is alphabetical. It contains all the topics included in this manual, along with the page(s) on which you can find each topic.

TOPIC	PAGE	TOPIC	PAGE
AIR CIRCULATION .....	10	MODEL AND SERIAL NUMBER .....	2
ANTI-TIP BRACKET .....	25	OVEN DOOR .....	34
ASSISTANCE .....	39	OVEN LIGHT .....	36
BAKING		OVEN TEMPERATURE	
AccuBake .....	14, 15	Adjusting .....	17
Pans .....	9, 10	Setting .....	14, 19
Preheating .....	15	OVEN VENT .....	25
Racks .....	9, 10	PANS .....	9, 10
Setting cycle .....	14	PARTS .....	6
Tips .....	16	RACKS .....	9, 10
BROILING		ROASTING	
Grid .....	19	Pans .....	9, 10
Guide .....	20	Racks .....	9, 10
Pan .....	18, 19	Setting cycle .....	14
Rack positions .....	20	Tips .....	15
Setting cycle .....	18	SAFETY .....	3-5
Tips .....	19	SELF-CLEANING CYCLE	
CLEANING		Before you start .....	27
Broiler pan and grid .....	31	Delay start .....	29
Control knobs .....	31	How the cycle works .....	30
Control panel .....	31	Setting the controls .....	28
Exterior surfaces .....	31	Tips .....	30
Oven cavity .....	32	Starting immediately .....	28
Oven door glass .....	32	Stopping the cycle .....	30
Oven racks .....	32	SERVICE .....	39
Self-cleaning cycle .....	27	STORAGE DRAWER .....	26
Surface burners .....	32, 33, 34	SURFACE BURNERS	
Surface burner grates .....	31	AccuSimmer .....	7
CONTROL PANEL		Control knobs .....	7, 31
Burner heat settings .....	7	Control setting guide .....	7
Celsius/fahrenheit .....	17	Power failure .....	8
Control knobs .....	7	Surface burner markers .....	6
Surface burner markers .....	6	Tips .....	7
COOKWARE		TIPS	
Canning .....	8	Bakeware .....	9
Tips .....	8	Broiling .....	19
ELECTRONIC OVEN CONTROL		Cookware .....	8
Canceling .....	13	Roasting .....	15
Clock .....	12	Saving energy .....	7, 16
Control lock .....	11	Self-cleaning .....	30
Display .....	11	TROUBLESHOOTING .....	37-38
Minute timer .....	12	WARRANTY .....	44
Starting .....	13		
Tones .....	14		
FEATURES .....	6		
MEALTIMER™ CONTROL			
Delay start .....	23		
Starting now .....	21		

# WARRANTY

## WHIRLPOOL® GAS RANGE

LENGTH OF WARRANTY	WHIRLPOOL WILL PAY FOR
<b>FULL ONE-YEAR WARRANTY</b> FROM DATE OF PURCHASE	FSP® replacement parts and repair labor to correct defects in materials or workmanship. Service must be provided by an authorized Whirlpool service company.
WHIRLPOOL WILL NOT PAY FOR	
<p><b>A.</b> Service calls to:</p> <ol style="list-style-type: none"> <li>1. Correct the installation of your range.</li> <li>2. Instruct you how to use your range.</li> <li>3. Replace house fuses or correct house wiring or plumbing.</li> <li>4. Replace owner-accessible light bulbs.</li> </ol> <p><b>B.</b> Repairs when your range is used in other than normal, single-family household use.</p> <p><b>C.</b> Pickup and delivery. Your range is designed to be repaired in the home.</p> <p><b>D.</b> Damage to your range caused by accident, misuse, fire, flood, acts of God, or use of products not approved by Whirlpool.</p> <p><b>E.</b> Repairs to parts or systems caused by unauthorized modifications made to the appliance.</p>	

3/96

**WHIRLPOOL CORPORATION SHALL NOT BE LIABLE FOR INCIDENTAL OR CONSEQUENTIAL DAMAGES.** Some states do not allow the exclusion or limitation of incidental or consequential damages, so this exclusion or limitation may not apply to you. This warranty gives you specific legal rights, and you may also have other rights which vary from state to state.

**Outside the United States, a different warranty may apply. For details, please contact your authorized Whirlpool dealer.**

If you need service, first see the “Troubleshooting” section of this book. After checking “Troubleshooting,” additional help can be found by checking the “Requesting Assistance or Service” section, or by calling the Whirlpool Consumer Assistance Center telephone number, **1-800-253-1301**, from anywhere in the U.S.A.